

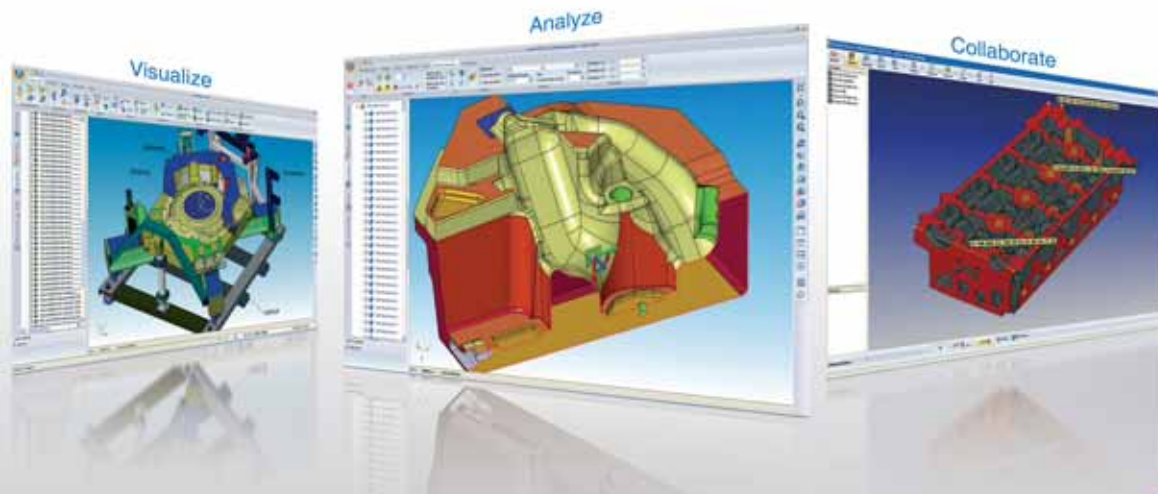

# WORKXPlore



**High Speed Collaborative Viewer**  
for analysis & exploration of all 3D CAD data

# WORKXPlore

## Sescoi's new industry specialist solution

**WorkXPlore 3D** is the ideal tool for directly displaying and analyzing 3D CAD files without the need for the original CAD applications. This remarkably easy to use software enables novice and experienced users alike to explore any type of standard or native 2D/3D CAD file

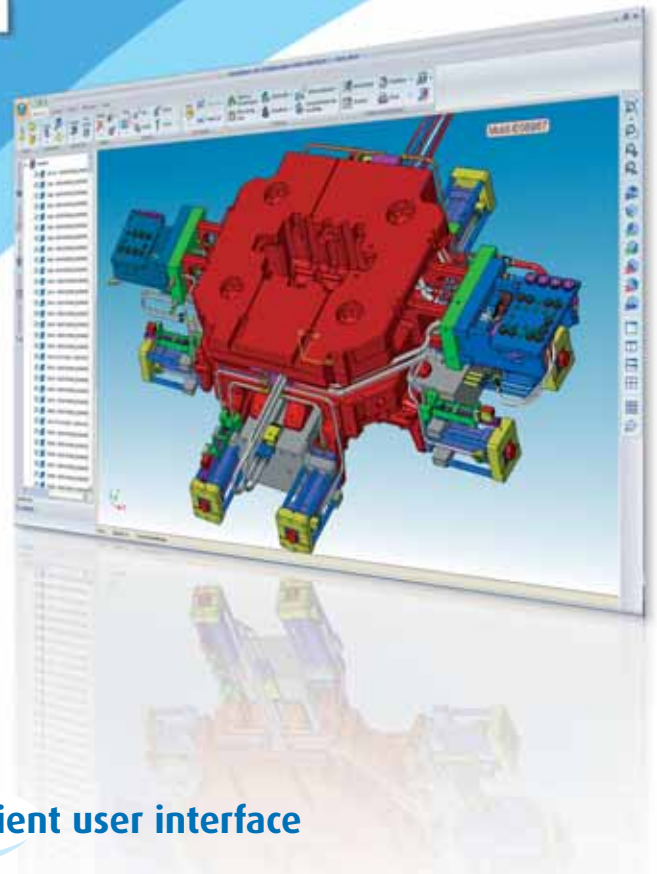

### A clear & efficient user interface

The clear, efficient interface gives users access to the full set of core functions directly from the home screen to ensure they are up and running with the software fast.

> **Total, high performance 3D model handling and display:** The software features predefined windows with various views (face, top, bottom, left, right, iso,...); dynamic zoom, rotation and scroll functions; several display modes : 3D, shaded, wireframe, hidden lines or textured; color transparency and visibility management for each object or surface in a 3D model.

> **Instant, easy access to key information :** WorkXPlore 3D provides quick access to an integrated file explorer, part or assembly tree structures as well as layer and scene management.

This management zone allows both CAD novices and experts to handle various 2D/3D entities or to access key characteristics of 2D files (layers, scenes, drag and drop file importation, ...) with total ease.

# Fast, direct import of 3D CAD files

## originating from multiple CAD systems into a single application

WorkXPlore 3D enables users to build virtual unified prototypes or 3D models from files imported from various CAD applications. Users can work on model set up and improvements before committing time and resources to creating a real prototype.

**A wide range of CAD interfaces are available:** Catia V5®, Catia V4®, Unigraphics®, Parasolid®, Pro/E®, Solidworks®, Solidedge®, Cadds®, IGES, STEP, Unisurf, STL (binary and ASCII), WorkNC® geometry, VRML, WorkNC® toolpaths, ISO toolpaths, DXF, DWG®, HPGL.

WorkXPlore 3D has been created for the efficient import and analysis of files of all sizes and types but it is **the speed at**

**which it imports large, and even very large, 3D CAD files** files which is particularly impressive, often taking less than half the time to open a file compared to the original CAD application!

**The software saves the native CAD data in its own lightweight "XPlore 3D" format (.a3D)** enabling users to calculate surface areas and volumes, measure thickness, dimensions and angles and much more without requiring the original CAD data. This lightweight format can be easily transmitted to other project members via email.

### > Key User Benefits :

**WorkXPlore 3D reads standard and native 2D/3D CAD files** originating from all well-known CAD applications that often entail expensive systems. WorkXPlore 3D users therefore save money by minimizing the need to acquire and run multiple CAD systems.

**High speed import and analysis of CAD files** result in considerable time savings compared to the use of the original CAD software.

**Extremely practical, lightweight format** enabling instant model analysis without the original CAD data and easy transmission of the file by email to any project member.

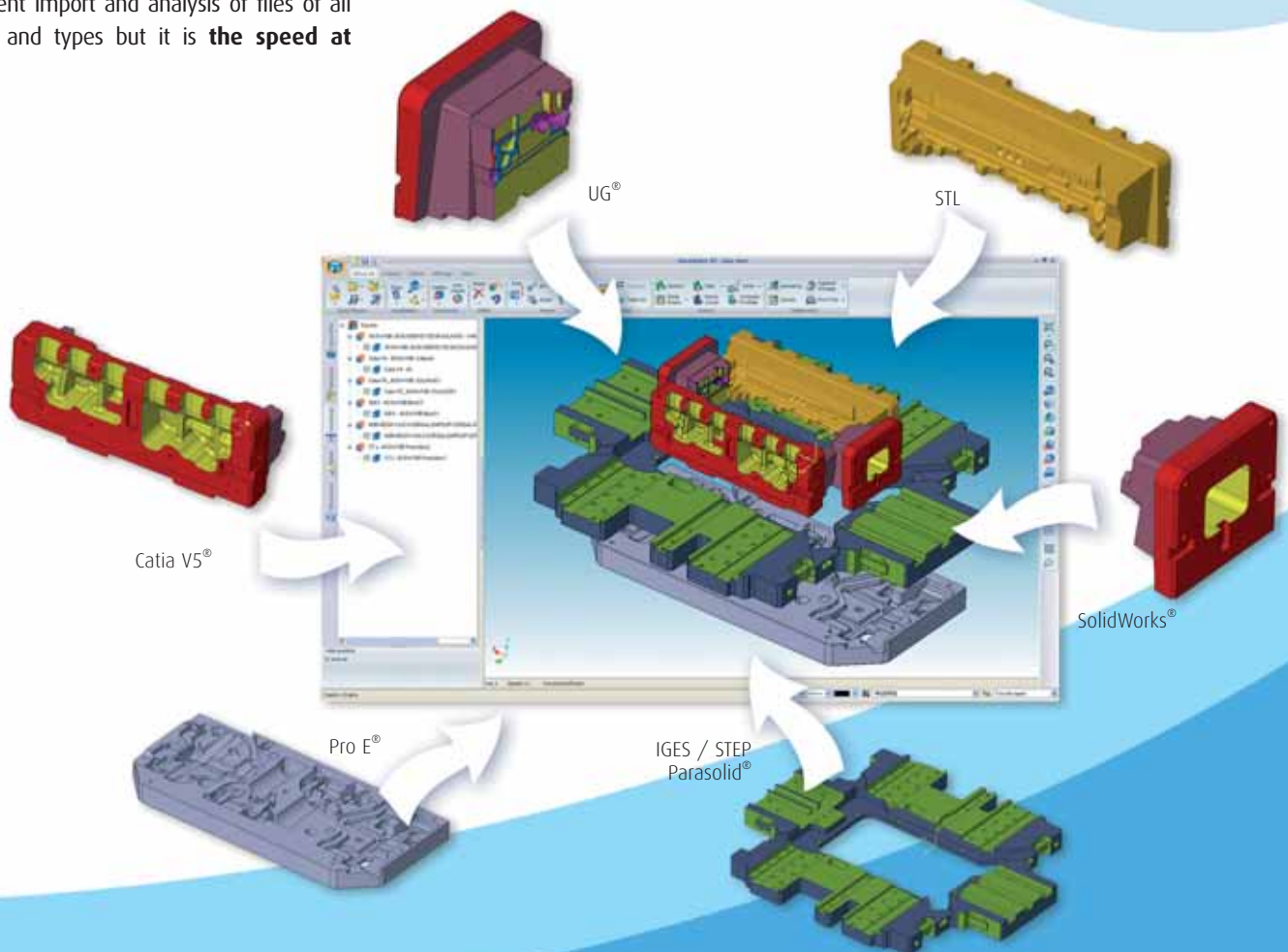

# Measurements, Annotations & Analyses

Specialist functions for smart  
3D model management

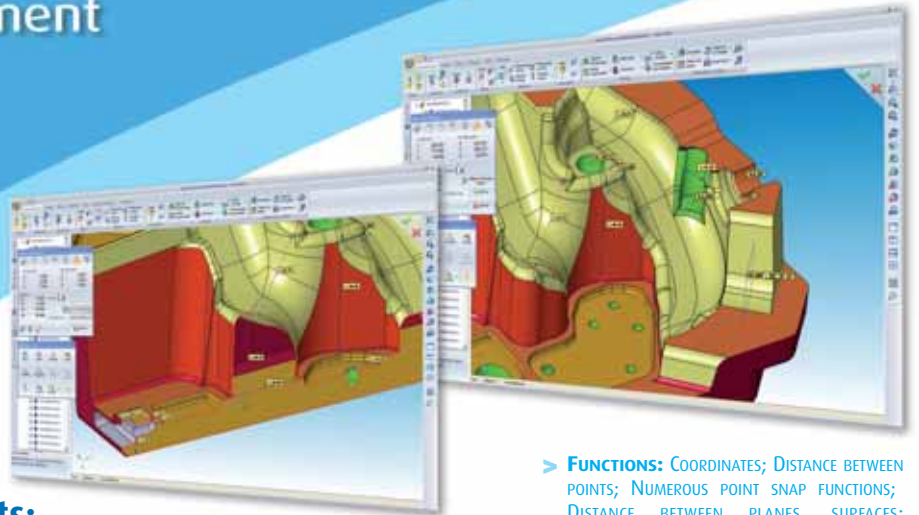

## Measurements:

WorkXPlore 3D features a wide range of 2D and 3D measurement functions that are highly accurate due to the high precision Brep 3D model employed.

Even non-expert CAD users can quickly get to grips with the software's measurement functions and obtain good results instantly by using the software's predefined selection modes (points, 2D entities, planes, surfaces, etc).

Measurements can be automatically included as measurement entities and can be anchored to characteristic points of the part. Entity labels automatically pivot to remain visible at all times.

WorkXPlore 3D's specialist measurement functions allow expert CAD users to recover point clusters from three-dimensional measuring equipment or machine probes and to quickly check data vis-à-vis the original CAD geometry. The software also allows users to easily generate control point files for transmission to three-dimensional measuring equipment or NC machines.

> **FUNCTIONS:** COORDINATES; DISTANCE BETWEEN POINTS; NUMEROUS POINT SNAP FUNCTIONS; DISTANCE BETWEEN PLANES, SURFACES; NUMEROUS PLANE SELECTION COMMANDS; MINIMUM DISTANCES BETWEEN ANY SURFACE GROUPS; ANGLE MEASUREMENTS; AUTOMATIC OR 3 POINT RADIUS/DIAMETER MEASUREMENT; MANUAL OR AUTOMATIC MEASUREMENT INSERTION; CONTROL BASED ON POINT CLUSTERS; CONTROL POINT CREATION USING PROBE RADIUS.



## Annotations :

WorkXPlore 3D offers a wide range of annotation functions. Users can convey their ideas, observations, instructions and change requests easily and quickly.

The need for 2D drawings is minimized as users can directly add dimensional and geometric measurements, annotations and labels to the 3D model.

> **FUNCTIONS:** SIMPLE AND MULTIPLE LABELS; OBJECT LABELS; Z FACE, RADIUS & COORDINATE LABELS; COMMENTS; 2D TEXTS; 3D TEXTS ON FACES, LINEAR, ANGULAR & CIRCULAR DIMENSIONING.

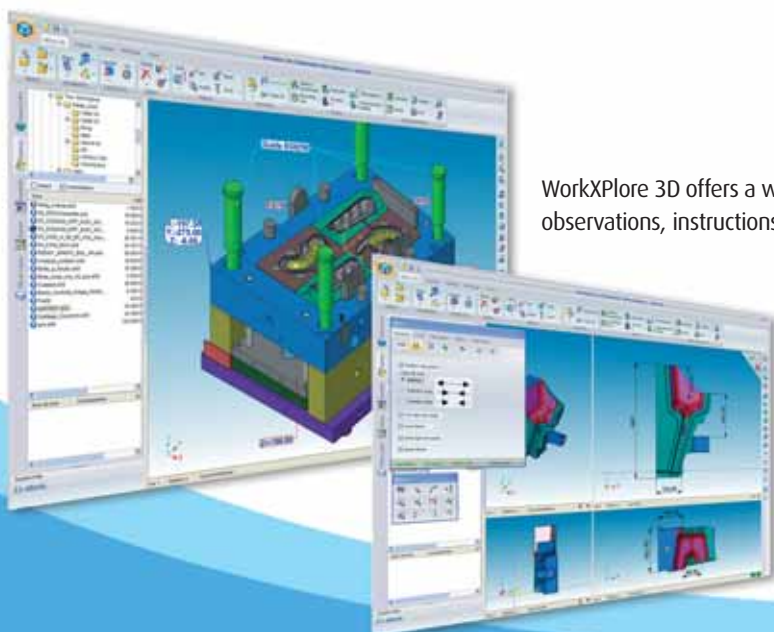

## Analyses:

**WorkXPlore 3D** comes with a full range of specialist analysis tools which can be used to help make quotes, diagnostics, assembly notes or for 3D models production preparation.

**WorkXPlore 3D** also offers a range of analysis functions which are usually only available with more costly CAD solutions. As well as being extremely fast and efficient (even on very large models), the software's functions are very easy to use with results being displayed in color on the 3D model. In a single mouse click, labels are automatically inserted on surfaces displaying accurate values resulting from various calculations.

> **FUNCTIONS:** DYNAMIC SECTIONING; BOUNDING BOX; DRAFT ANGLES; CURVATURE ANALYSIS; PLANE FACE ANALYSIS; AUTOMATIC 3D MODEL COMPARISON; FACE AND OBJECT INFORMATION.

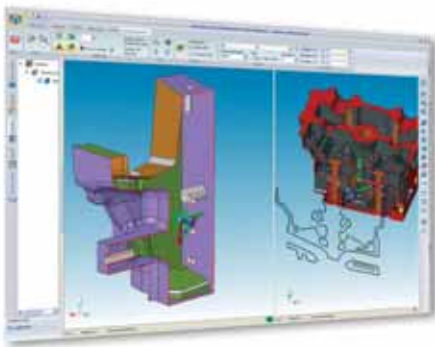

**High performance dynamic sectioning:** allows users to explore inside a part or an assembly easily and accurately. The dynamic reference controller allows users to control the section plane with the mouse in rotational and panning directions or following a guide curve. The cross section can be made visible on the 3D model or as an isolated entity and can be extracted and exported via the DXF, DWG, etc interfaces.

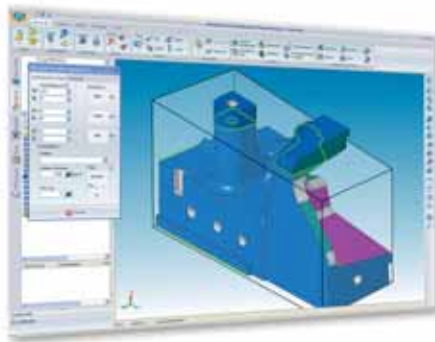

Generation of the **bounding box** of a part or a set of parts is instantaneous and provides information on the dimensions, volume and weight of the selected elements and can also be used to determine the optimal stock model required for manufacturing.

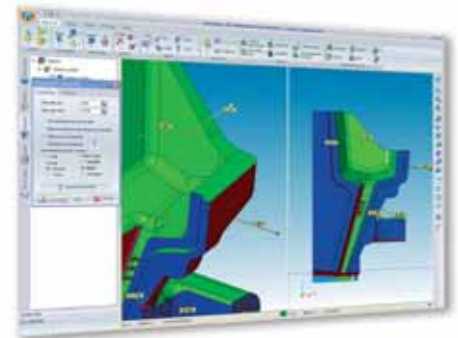

The calculation and display of **drafts and undercuts** are extremely quick, even on very big parts. WorkXPlore 3D automatically colors drafts and undercuts according to the mold stripping axis. Precise draft angle values are displayed dynamically as the mouse is dragged over the surfaces and can be inserted by default in the 3D model.

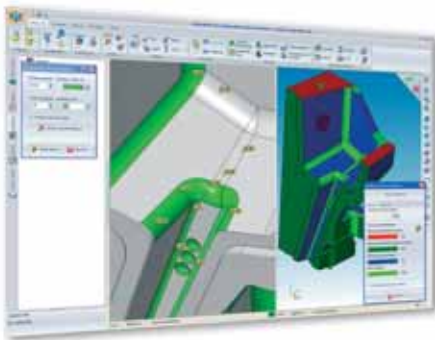

**Curvature radius and plane face analysis** is a valuable tool for users enabling fast cost and production time evaluation. The coloring of elements to be analyzed is automatic and users can insert measurement labels containing precise values of the elements selected.

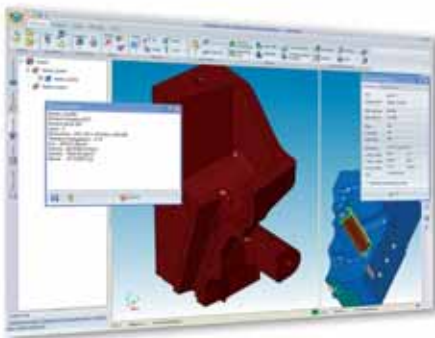

**Precise measurement information:** Information is available both on objects and surfaces and enables rapid calculation of volumes and areas. Complementary information such as the object name, encumbrance, number of faces, etc. is also available.

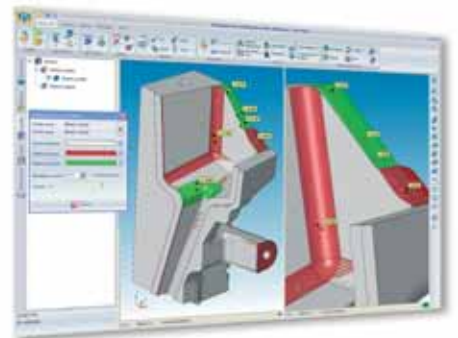

**Automatic 3D part comparison** allows real time 3D graphic display of the differences between two versions. Modifications are clearly identified by different colors to distinguish between material added and material removed.

# Animation, documentation & publication

3D files with design and manufacturing data included

## Animation:

WorkXPlore 3D includes a fully functional animation kernel allowing users to generate exploded views or animated assembly movements. Setting up animations is achieved by simply initiating basic movements such as translation, rotation or following a guide curve.

### Interference detection:

Dynamic collision analysis functions can be used during animations to carry out real time control of mechanism interoperability or process control.

Users can also generate short videos directly from the animation menu that can then be shown to customers or other project members.

> **FUNCTIONS:** ANIMATION CREATION, BOUNDING BOX, DRAFT ANGLES, CURVATURE ANALYSIS, PLANE FACE ANALYSIS, AUTOMATIC 3D MODEL COMPARISON.

## Documentation:

With WorkXPlore 3D users can generate screen captures to illustrate technical documents and assembly sheets.

In addition to the traditional screen capture functions, WorkXPlore 3D features an image collector which also allows users to easily manage and distribute large volumes of images.

> **FUNCTIONS :** CAPTURE BY WINDOW OR BY ZONE; AUTOMATIC TRANSFER TO FILES, APPLICATIONS, CLIPBOARD, MESSAGE SYSTEMS; IMAGE COLLECTOR.



## Publication:

WorkXplore 3D allows users to easily share their CAD models throughout the entire design and manufacturing chain, with all project members whether they are product managers, marketing, sales, outside manufacturing consultants, customers or suppliers.

### Creation of predefined scenes:

Whatever their CAD software skill level, it is important for company staff to be able to use communication tools that capture their personal expertise and enable this to be exploited by other staff members.

Predefined scenes have therefore been created and stored in the software. The configurations, orientations and views of these scenes are saved in a fixed state along with related annotations, dimensions and labels. Users can then simply navigate from screen to screen to find the configuration preferred by the creator of the scenes.

### Export:

With WorkXplore 3D users can quickly convert standard or native 3D models via the available export interfaces (IGES, STL, URML, WorkNC CAM geometry). Brep models can also be saved under the IGES format ...

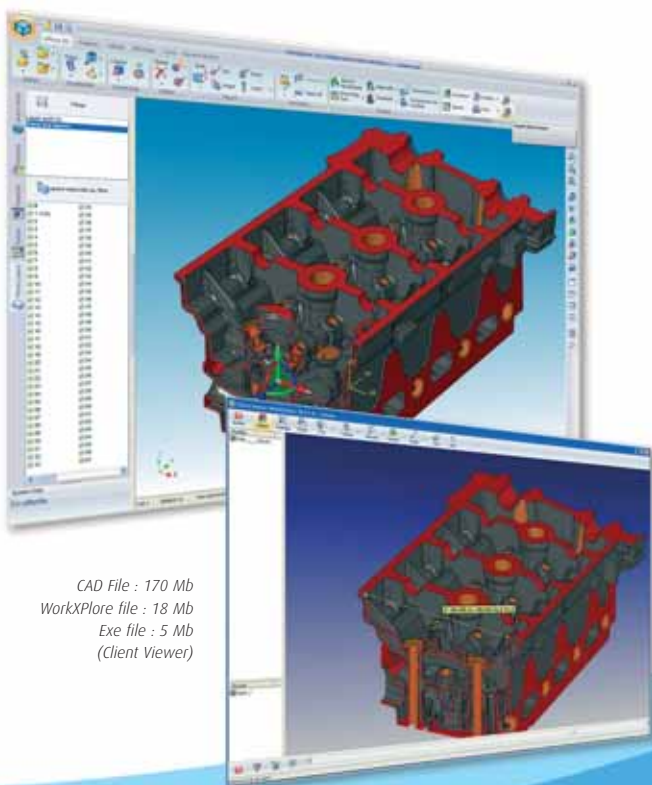
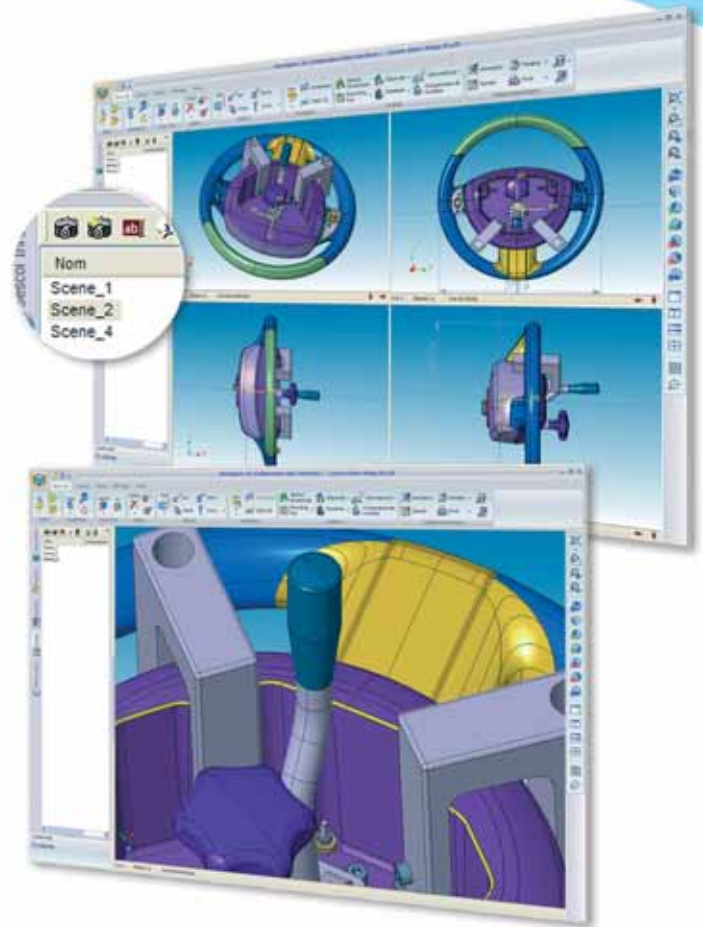

CAD File : 170 Mb  
WorkXplore file : 18 Mb  
Exe file : 5 Mb  
(Client Viewer)

### Collaborate :

Users need no longer worry about format compatibility or what software their partners use! WorkXplore 3D enables users to communicate 3D parts and assemblies to sub-contractors, customers or colleagues using a standalone, lightweight application that can be easily transmitted via the Internet. The recipient can immediately display and work on the 3D model without requiring the original CAD data.

Furthermore, user access protection can be applied to ensure that only the right people see the right data.

Download evaluation version and free viewer  
[www.workxplore-3d.com](http://www.workxplore-3d.com)

**Sescoi®** was founded in 1987 with the mission of developing the most automatic, the most reliable, and the most easy to use manufacturing software solutions on the market.

The company develops **WorkNC®** - the world leading automated CAM/CAD system for 2 to 5 axis machining, **WorkNC-CAD®** - easy to use manufacturing CAD software, **WorkPLAN Enterprise®** - a new generation ERP system for custom manufacturers and **MyWorkPLAN®** - a job management system for companies that work on a project basis.

With many years' business, engineering, and software development experience, Sescoi has an intimate understanding of customers' requirements and helps them master the challenges of improving their productivity, reducing their costs and building their business long term.

#### **SESCOI USA INC.**

2000 Town Center, Suite 1730  
48075 Southfield - Michigan  
**USA**

Tel. (+1) 248 351 9300  
Fax (+1) 248 351 9301  
[info@sescoi.com](mailto:info@sescoi.com)

#### **SESCOI INTERNATIONAL UK CUSTOMER SERVICES**

PO Box 14562, Trinity Place,  
Midland Drive, Sutton Coldfield  
B73 9PP West Midlands

**UNITED KINGDOM**  
from UK : Tel. 0844 561 7014  
outside UK : Tel. (+44) 121 323 5465  
[info@sescoi.co.uk](mailto:info@sescoi.co.uk)

#### **SESCOI FRANCE SAS & SESCOI INTERNATIONAL SAS**

Boulevard du Général de Gaulle  
71009 Macon Cedex

**FRANCE**  
Tel. (+33) (0)385216621  
Fax (+33) (0)385216622  
[info@sescoi.fr](mailto:info@sescoi.fr)

#### **SESCOI GMBH**

Schleussner Strasse 90-92  
D-63263 Neu-Isenburg

**GERMANY**  
Tel. (+49) (0)6102 71440  
Fax (+49) (0)6102 714456  
[info@sescoi.de](mailto:info@sescoi.de)

#### **SESCOI IBERIA**

C/ Narcis Monturiol, 2, Planta 4  
08960 Sant Just Desvern - Barcelona

**SPAIN**  
Tel. (+34) 93 480 2455  
Fax (+34) 93 473 4219  
[info@sescoi.es](mailto:info@sescoi.es)

#### **SESCOI KK**

Kamiyacho Plaza Bldg. 3F 4-1-14  
Toranomon Minato-ku 105-0001 - Tokyo

**JAPAN**  
Tel. (+81) 3 3578 0025  
Fax (+81) 3 3578 0026  
[info@sescoi.co.jp](mailto:info@sescoi.co.jp)

#### **SESCOI INDIA SOLUTIONS PRIVATE LIMITED**

Q-401, 4TH FLOOR 244,  
MAYUR TRADE CENTER,  
MUMBAI PUNE HIGHWAY CHINCHWAD  
Pune 411 019

**INDIA**  
Tel. (+91) 20 46701586  
Fax (+91) 20 46701587  
[india@sescoi.com](mailto:india@sescoi.com)

#### **SESCOI CHINA**

Room 14B, NO.450 Fu Shan Road,  
Pudong New Area - Shanghai 200122

**CHINA**  
Tel. (+86) 21 58 30 37 19  
Fax (+86) 21 58 30 36 64  
[info@sescoi.cn](mailto:info@sescoi.cn)



[www.workxplore-3d.com](http://www.workxplore-3d.com)

DOWNLOAD EVALUATION VERSION AND FREE VIEWER