



WorkNC[®]

G3 V20

V20

New Features and Enhancements

WorkNC - Automatic CAM/CAD System
for 2 to 5-axis machining

Sescoi[®]
www.sescoi.com

CAD Compatibility & Import

Import and automatic recognition of CATIA V5® 3D Features:

WorkNC now features import and automatic recognition of CATIA V5® drilling features. In WorkNC's automatic drilling module, holes are automatically associated with the various types of predefined drilling sequences.

- > Features processed: Standard drilling, Conic Drilling, Counterboring, Chamfering, Counterdrilling.
- > Automatic association of WorkNC drilling strategies.

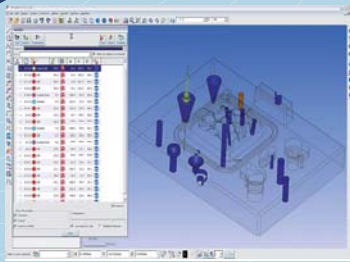

Enhancement and update of DXF/DWG Import®:

- > Direct import of DWG and DXF files from different versions of AutoCAD or AutoCAD-compatible software.
- > Compatible with most recent versions from version 11 onwards.

New: WorkNC V20 includes a complementary SolidWorks direct translator

(part and assembly reading)

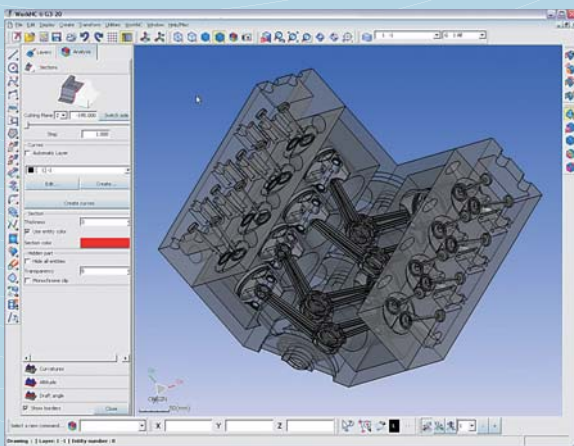

Transform your productivity with WorkNC V20's new machining functions & toolpaths

Advanced stock model management:

WorkNC boasts the most advanced, efficient stock model management functionality on the market, thanks largely to its dynamic stock model management that updates in real time during roughing toolpath calculations. Sescoi now widens the gap between WorkNC and other CAM systems by further optimizing WorkNC's stock model management functions.

>Intermediate stock model management:

In V20, WorkNC saves all the intermediate stock models and updates only the stock model for modified toolpaths and those following it. This function results in significantly reduced calculation times when modifying toolpaths in large machining projects.

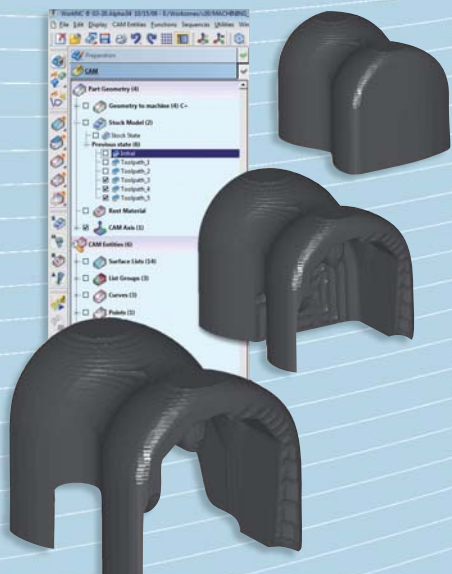

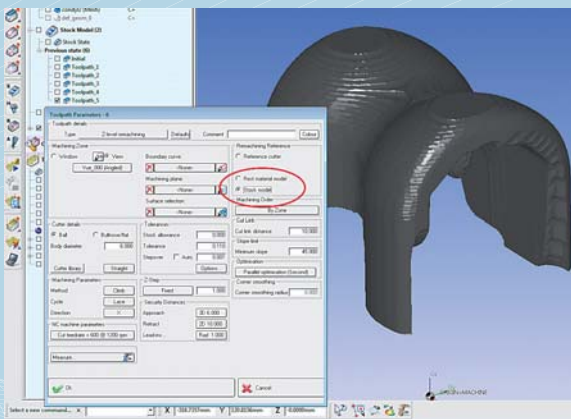
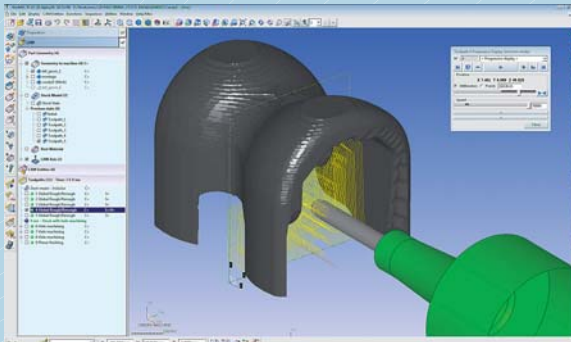

➤ All types of toolpaths can be used to update the 3D stock model:

As well as stock model updating being possible with all toolpaths (finishing, optimization, ...), the user can obtain and display the stock model in real time, even with 3+2 toolpaths.

➤ Use of the 3D stock model for rest material re-machining:

This new function, available for all re-machining toolpaths, detects the rest material based on the current 3D stock model. For optimum results, this model must be updated with all the intermediate toolpaths.

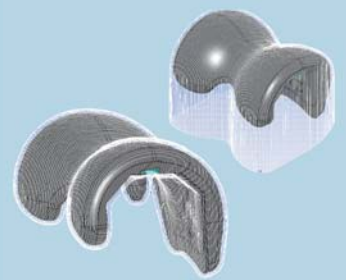

➤ And, in addition:

- Dynamic creation of user stock models (cubic and cylindrical),
- Multidirectional 3D stock model initialization (6 views),
- High definition 3D stock model display,
- Direct import of a stock model from one workzone to another,
- Use of the 3D stock model for automatic drilling,
- New Tool library.

Greatly reduced programming and toolpath recalculation times:

WorkNC V20 can perform partial toolpath recalculation. This function results in significantly reduced calculation times, e.g. up to 75% when simply changing the type of lead-in/lead-out.

Improved 2.5 axis toolpaths and optimized manual drilling with WorkNC's automatic features recognition module ...

➤ Interactive manual drilling:

The automatic hole machining features recognition module, along with the automatic drilling function, have been enhanced in WorkNC V20 by the addition of a high performance, intuitive manual drilling mode.

Users can create specific drilling cycles based on the geometry of detected holes.

➤ Enhanced 2.5 axis toolpaths:

Tangent to Curve and Curve Re-machining toolpaths now make allowance for tool compensation. Pocket machining functionality is also enhanced to handle both closed and open pockets and also features a new, highly efficient pocketing strategy.

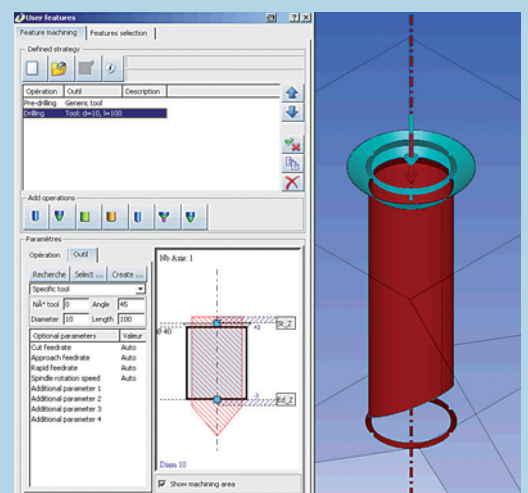
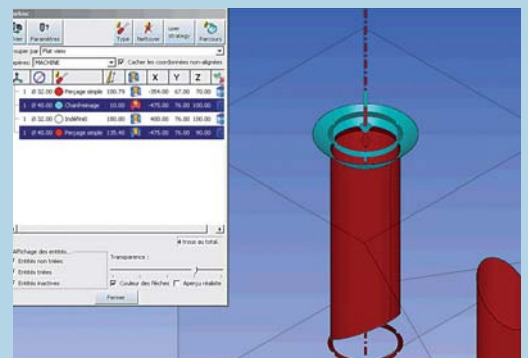

New and enhanced 3-axis and 3+2 axis HSM toolpaths:

WorkNC's new and enhanced roughing and finishing toolpaths bring step increases in productivity. Improved surface finish quality is a highlight of the new finishing toolpaths.

> Improved Global Roughing toolpaths for small and very small parts or details:

In WorkNC V20, the user can now define very small stepovers (0.05mm) for Global Roughing and Re-roughing toolpaths. This new feature ensures optimal protection for small tools with tiny diameters (less than 1mm diameter).

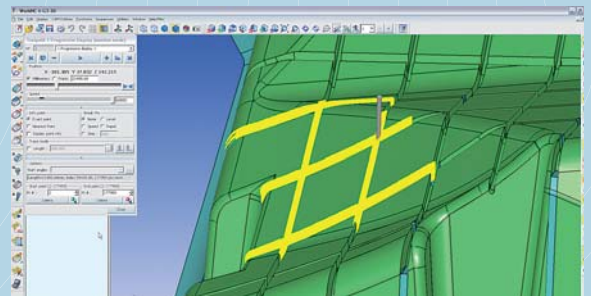

> Global Finishing (*new toolpath*):

A single toolpath can now be used to machine the whole part. The Global Finishing toolpath handles both walls and flat areas and always machines in climb mode. The trajectory adopts a spiral movement with a constant stepover on the surface wherever possible.

This new toolpath also greatly reduces the number of retracts preventing parts from being accidentally marked. The number of lead-ins and lead-outs and feedrate changes are also significantly reduced, lengthening tool service life and optimizing High Speed Machining (HSM).

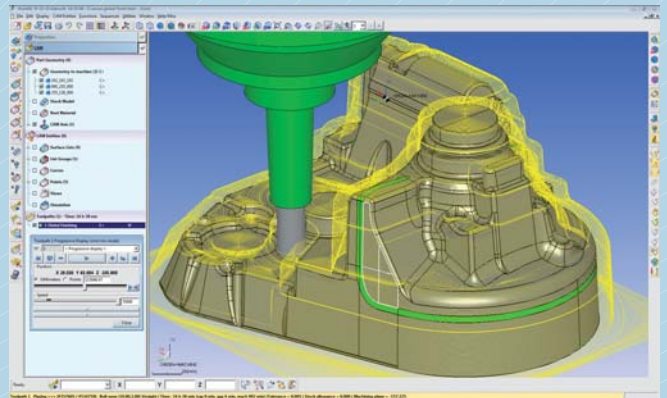

> Undercut Finishing (*new toolpath*):

This new toolpath enables undercut areas to be machined with a lollipop cutter in 3 axis and 3+2 axis modes. If the tool used is a standard cutter that does not allow machining of undercut areas in the 3 axis mode, the toolpath is automatically converted into a 5 axis toolpath with automatic elimination of collisions.

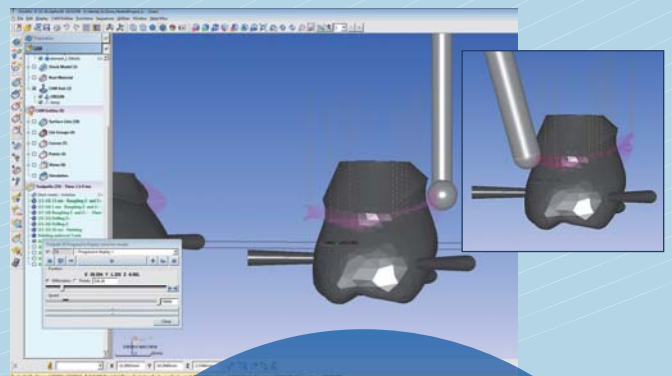

> Re-roughing strategies integrated in Trochoidal and Spiral Roughing toolpaths:

The re-roughing strategies which have been integrated in the Trochoidal and Spiral Roughing toolpaths reduce machining times by between 20 to 50%, ensuring optimal security and use of the total effective cutting height of the tool.

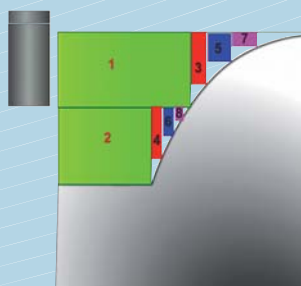

> And, in addition:

- Use of reinforced cutters with roughing toolpaths,
- Pocket detection management in optimization toolpaths,
- Z Level Finishing and Optimized Z Level Finishing toolpaths merged into one single toolpath,
- Use of conic tools in Z Level Finishing.

New 5 axis toolpaths and enhancements to 'Auto 5', WorkNC's automatic 5 axis module

> 5-axis: 3D Surface Finishing (new toolpath):

This new 5 axis finishing toolpath generates a normal to surface toolpath using a particularly efficient spiral strategy which ensures optimal quality and machining conditions on complex parts including undercut areas.

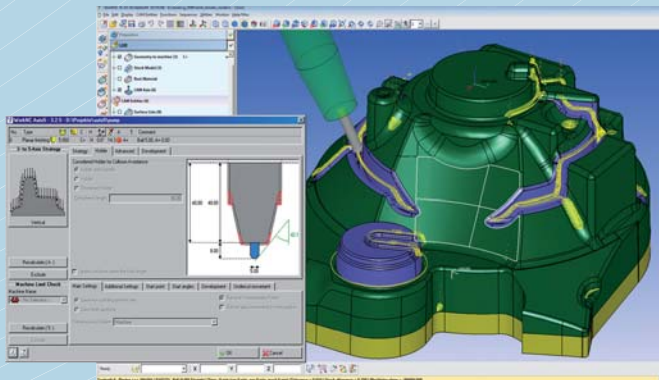
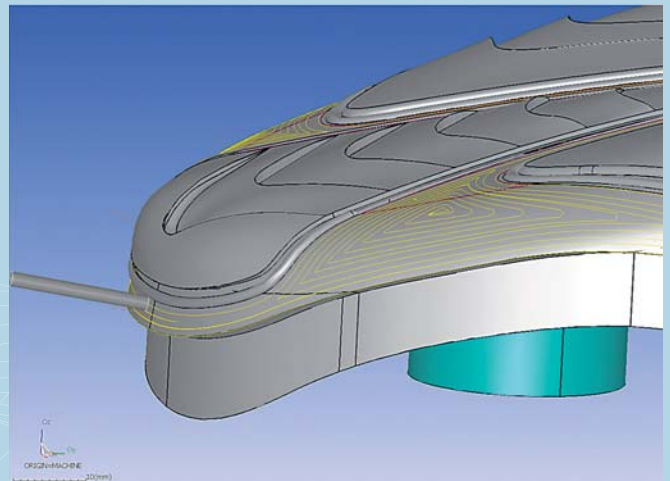

> Re-engineered 'Auto 5' module:

WorkNC's Auto 5 automatically converts 3-axis toolpaths into simultaneous 5-axis toolpaths.

The Auto 5 module has been re-engineered with the introduction of an even more powerful calculation engine associated with a new collision detection and avoidance module. The improved calculation times can be 3 to 5 times faster depending on the complexity of the part.

Ergonomics have also been improved with direct display of tool holder collisions and the minimal tool length required to machine the whole part.

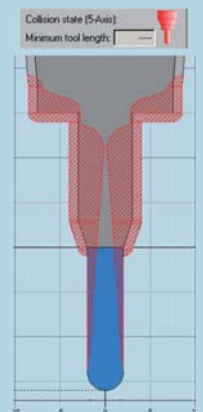

> New Automatic Strategy: Auto 3+2:

This new strategy enables the automatic conversion of a 3 axis toolpath into a 3+2 axis toolpath containing several machining zones according to the various, automatically created views. WorkNC automatically determines the number of 3+2 views required to generate the collision free toolpath.

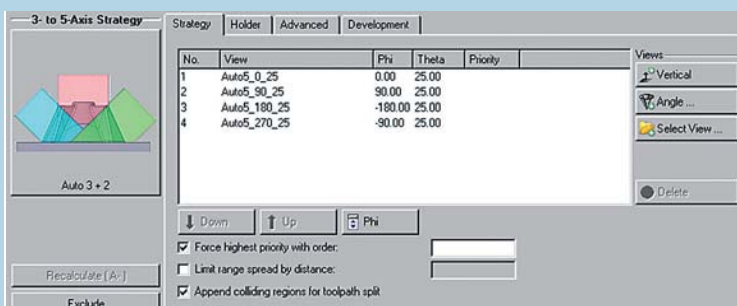

> And, in addition:

- Improved ergonomics for the 5-Axis Rolling toolpath,
- Auto 5 manages collisions in undercut areas on 5-axis toolpaths.

Productivity optimized with WorkNC G3 interface tools

> Dynamic collision analysis:

During the simulation process, WorkNC V20 now carries out powerful, real time collision analysis and detection between mobile elements.

The user can graphically select the elements to be included in the collision detection analysis.

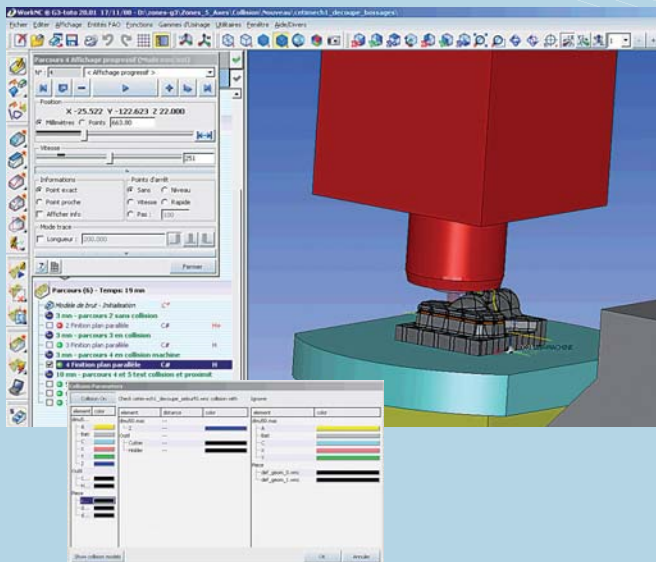

> Dynamic tool orientation for 3+2 machining zone selection:

This new function allows the tool to be dynamically moved across part surfaces in a given orientation.

The orientation is defined by the user (normal to surfaces, at an angle, ...) in order to determine the most advantageous positions for 3+2 machining.

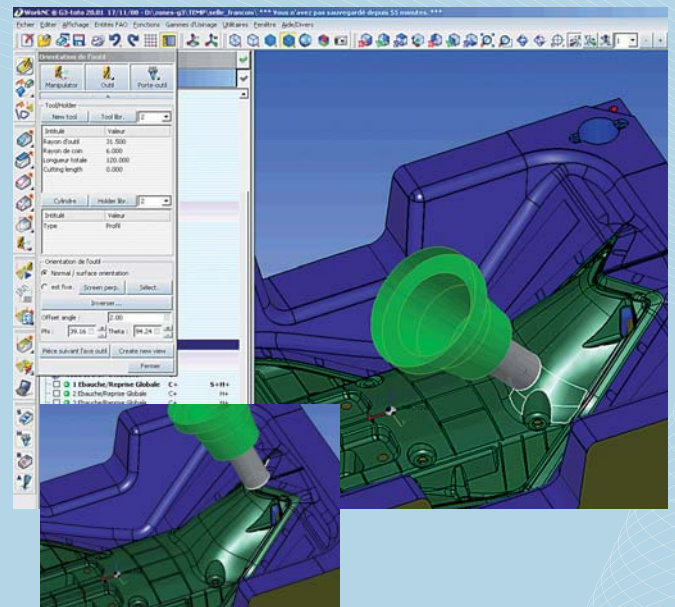

> 5 Axis toolpath edit mode:

WorkNC's edit mode functions, already available in WorkNC G3 for 3 axis toolpaths, can now be applied to 5 axis toolpaths. Toolpaths can easily be partially or totally isolated, removed, etc., without having to rerun calculations.

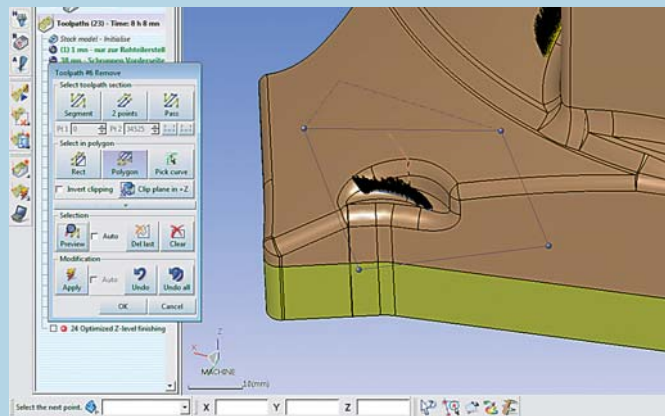

> Enhanced stock model display (calculation and simulation):

3D stock model solid block simulation is highly efficient and enables real time 3D simulation but in the past display quality sometimes suffered. WorkNC V20 now features clearer and more accurate 3D simulation display.



> And, in addition:

- New optimized tool + toolholder collision detection module,
- Geometry type classification,
- Use of stock model for simulation,
- New workzone management functions.

New CAD functions within the integrated WorkNC G3 environment

> New function for creating surface fillets:

WorkNC V20 features an efficient, user-friendly function for creating surface fillets with a simple, easy to use dialog box and a dynamic fillet preview with automatic restriction.

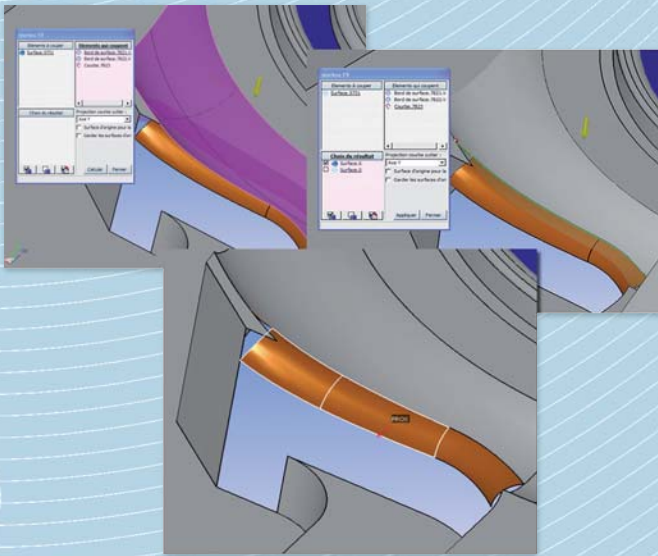

> New dynamic restriction function:

The new dynamic restriction function improves trimming performance and reliability. The simplicity and interactivity of the interface make this function very intuitive to use.

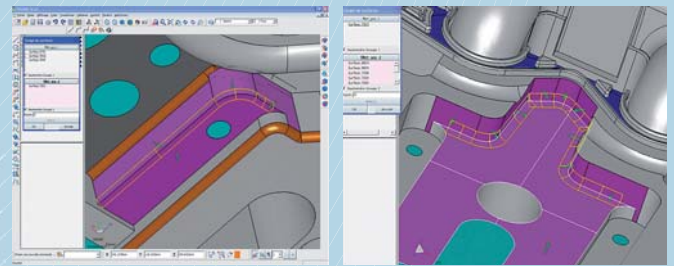

> Automatic surface hole patching:

This function brings CAM users significant preparation time savings. In just a few mouse clicks, all the holes in a complex surface can be patched.

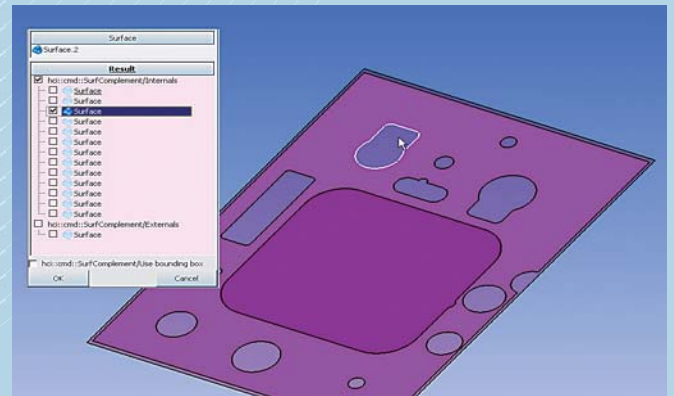

Smart WorkNC G3 Utilities

> Enhancements to Pack & Go, the WorkNC workzone archiving tool:

Pack & Go now includes multi-project support for data compression/decompression in batch mode and displays an image of each archived project.

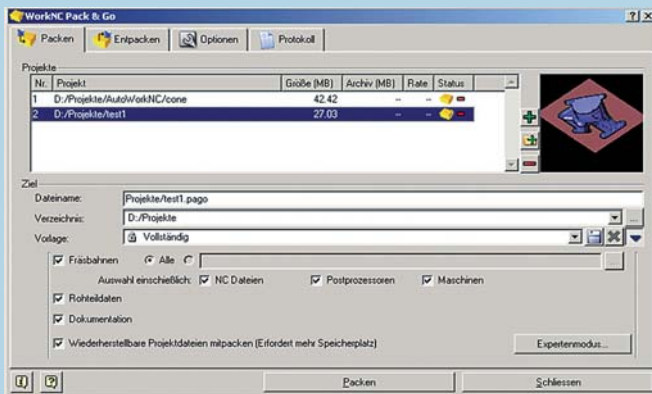

> New: Check & Go:

WorkNC Check & Go performs 3+2 axis and/or 5 axis machinability checking for a given machine and a specific fixture set-up and includes a best fixture set-up search (to minimize machine movements).

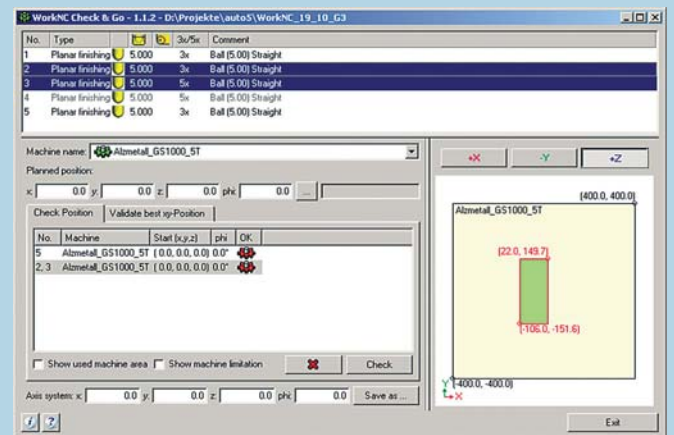

WorkNC®

G3 v20

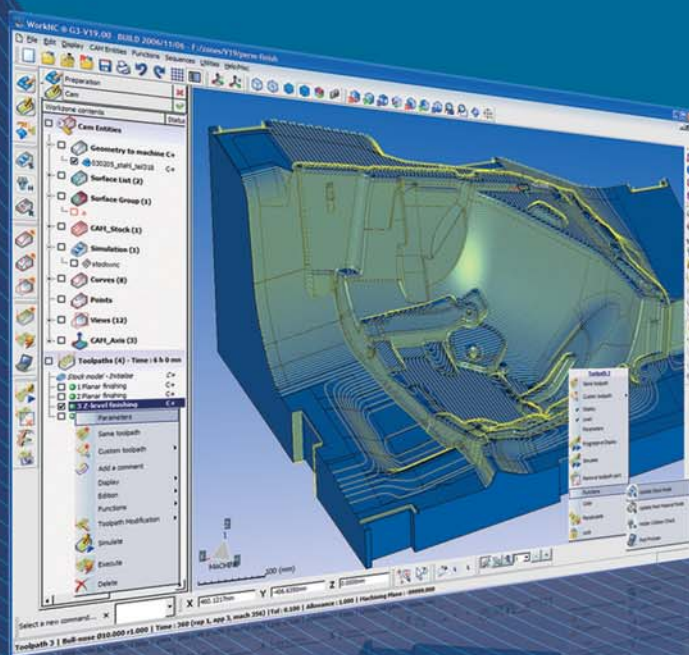

Sescoi International SAS - Boulevard du Général de Gaulle - 71009 Macon Cedex - France
Tel. (+33) (0)385216621 - Fax (+33) (0)385216622 - international@sescoi.fr